

**OWNER'S  
INSTRUCTION MANUAL**



**CALLER ID TYPE II  
MULTI-FEATURE TELEPHONE  
MODEL 9120**

**CORTELCO**

**THANK YOU  
FOR PURCHASING THE  
9120 CALLER ID TYPE II  
MULTI-FEATURE TELEPHONE**

**We want you to know all about your new Telephone**, how to install it, the features it provides, and the services you can expect from its use. We have included this information in your Owner's Instruction Manual.

**PLEASE READ BEFORE INSTALLING  
AND USING YOUR NEW TELEPHONE EQUIPMENT.**

# Table Of Contents

|  |           |
|--|-----------|
| <b>IMPORTANT SAFETY INSTRUCTIONS .....</b>       | <b>5</b>  |
| <b>TELEPHONE PART IDENTIFICATION .....</b>       | <b>7</b>  |
| <b>INSTALLATION .....</b>                        | <b>9</b>  |
| BOX CONTENTS .....                               | 9         |
| BATTERY INSTALLATION .....                       | 9         |
| DIALING MODE .....                               | 9         |
| WALL MOUNT .....                                 | 9         |
| DESK MOUNT .....                                 | 10        |
| ANSWERING MACHINE .....                          | 10        |
| RINGER VOLUME .....                              | 10        |
| MODEMS AND FAX MACHINES .....                    | 10        |
| <b>UNIT SETUP .....</b>                          | <b>11</b> |
| <b>BASIC OPERATION .....</b>                     | <b>13</b> |
| RECEIVING A PHONE CALL .....                     | 13        |
| PLACING A PHONE CALL .....                       | 13        |
| PREDIAL .....                                    | 13        |
| HEADSET .....                                    | 13        |
| CALL TIMER .....                                 | 13        |
| <b>FEATURE BUTTONS .....</b>                     | <b>14</b> |
| REDIAL/PAUSE BUTTON .....                        | 14        |
| FLASH BUTTON .....                               | 14        |
| AUTO DIAL BUTTON .....                           | 14        |
| MUTE BUTTON .....                                | 14        |
| MENU BUTTON .....                                | 14        |
| DELETE BUTTON .....                              | 14        |
| SAVE BUTTON .....                                | 14        |
| ENTER/DIAL BUTTON .....                          | 14        |
| MEMORY 1 and MEMORY 2 BUTTONS .....              | 15        |
| MESSAGE BUTTON .....                             | 15        |
| HOLD BUTTON .....                                | 15        |
| <b>SPEED DIAL .....</b>                          | <b>16</b> |
| STORE NEW NUMBERS IN MEMORY 1 AND MEMORY 2 ..... | 16        |
| Method 1 .....                                   | 16        |
| Method 2 .....                                   | 16        |
| Method 3 .....                                   | 16        |
| DIAL A NUMBER FROM MEMORY 1 OR MEMORY 2 .....    | 16        |
| REVIEW THE CONTENTS OF A MEMORY BUTTON .....     | 16        |
| STORE NEW NUMBERS IN TWO-TOUCH LOCATION .....    | 16        |
| DIAL A NUMBER FROM TWO TOUCH MEMORY .....        | 16        |

|  |           |
|--|-----------|
| REVIEW THE CONTENTS OF A TWO-TOUCH MEMORY .....    | 17        |
| <b>PHONE BOOK .....</b>                            | <b>17</b> |
| ADDING AN ENTRY TO THE PHONE BOOK .....            | 17        |
| REVIEWING PHONE BOOK ENTRIES .....                 | 17        |
| DIALING FROM THE PHONE BOOK .....                  | 17        |
| DELETING A PHONE BOOK ENTRY .....                  | 18        |
| STORING A CALLER ID RECORD IN THE PHONE BOOK ..... | 18        |
| <b>CALLER ID .....</b>                             | <b>18</b> |
| RECEIVING CALLS .....                              | 18        |
| PRIVATE CALLS .....                                | 18        |
| CALLER ID ON CALL WAITING .....                    | 19        |
| REVIEWING CALLS .....                              | 19        |
| DELETING CALLS .....                               | 19        |
| CALL BACK .....                                    | 19        |
| <b>TROUBLESHOOTING .....</b>                       | <b>20</b> |
| TELEPHONE REPAIR .....                             | 21        |
| <b>FCC INFORMATION .....</b>                       | <b>22</b> |
| <b>LIMITED WARRANTY .....</b>                      | <b>24</b> |

# IMPORTANT SAFETY INSTRUCTIONS

**Always follow basic safety precautions** when using your telephone equipment to reduce the risk of fire, electrical shock, and injury.

1. **Read and understand all instructions** in the Owner's Instruction Manual.
2. **Read all warnings** and follow all instructions marked on the product.
3. **Unplug this product from the wall outlet before cleaning.** Use a damp cloth for cleaning. Do not use liquid or aerosol cleaners.
4. **Do not use the telephone near water.** For example, do not use near a bathtub, wash bowl, kitchen sink, laundry tub, swimming pool, or in a wet basement.
5. **Do not place this product on an unstable cart or stand.** The product may fall causing serious damage to the product.
6. **Use only the type power source indicated on the label.** If you are not sure of the type power supply to your home, consult your dealer or local power company.
7. **Do not place any objects on the telephone line cord.** Do not locate the telephone where the line cord will be walked on.
8. **Do not block or cover ventilation slots and openings** in the bottom of the telephone. The openings should never be blocked by placing the telephone on a bed, sofa, rug, or other similar surfaces. The telephone should never be placed near or over a radiator or heat register. The telephone should never be placed in a built-in installation unless proper ventilation is provided.
9. **Never spill liquid on the telephone or push objects of any kind through ventilation slots.** Liquid or objects may touch dangerous voltage points or short out parts that could result in a risk of fire or electrical shock.
10. **Do not disassemble this product.** Opening or removing covers may expose you to dangerous voltages or other risks. Incorrect reassembly can cause electrical shock when the product is subsequently used.
11. **Do not overload outlets and extension cords.** Some telephones require AC power from an outlet. Overloading the outlets can result in the risk of fire or electric shock.
12. **Avoid using a telephone during a local thunderstorm.** There may be a remote risk of electrical shock from lightning.
13. **Do not use a telephone to report a gas leak in the vicinity of the leak.**

14. **Unplug the telephone from the wall outlet and refer servicing to qualified service personnel** under the following conditions:
- When the line cord is frayed or plugs damaged.
  - If liquid has been spilled into the telephone.
  - If the telephone has been exposed to rain or water.
  - If the telephone does not operate properly by following the operating instructions. (Adjust only those controls covered by the operating instructions. Improper adjustment of other controls may result in damage and will often require extensive work by a qualified technician to restore the product to normal operation.)
  - If the telephone has been dropped or the housing damaged.
  - If the telephone exhibits distinct change in performance.

**SAVE THESE INSTRUCTIONS**

## TELEPHONE PART IDENTIFICATION

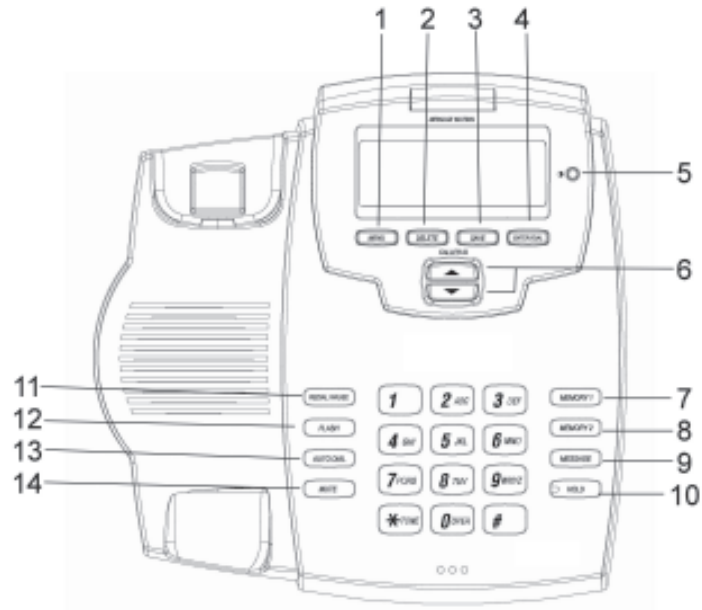

|                       |                        |
|-----------------------|------------------------|
| 1 Menu Button         | 8 Memory 2 Button      |
| 2 Delete Button       | 9 Message Button       |
| 3 Save Button         | 10 Hold Button         |
| 4 Enter/Dial Button   | 11 Redial/Pause Button |
| 5 LCD Contrast Button | 12 Flash Button        |
| 6 Up and Down Buttons | 13 Auto Dial Button    |
| 7 Memory 1 Button     | 14 Mute Button         |

# TELEPHONE PART IDENTIFICATION

## Back and Side

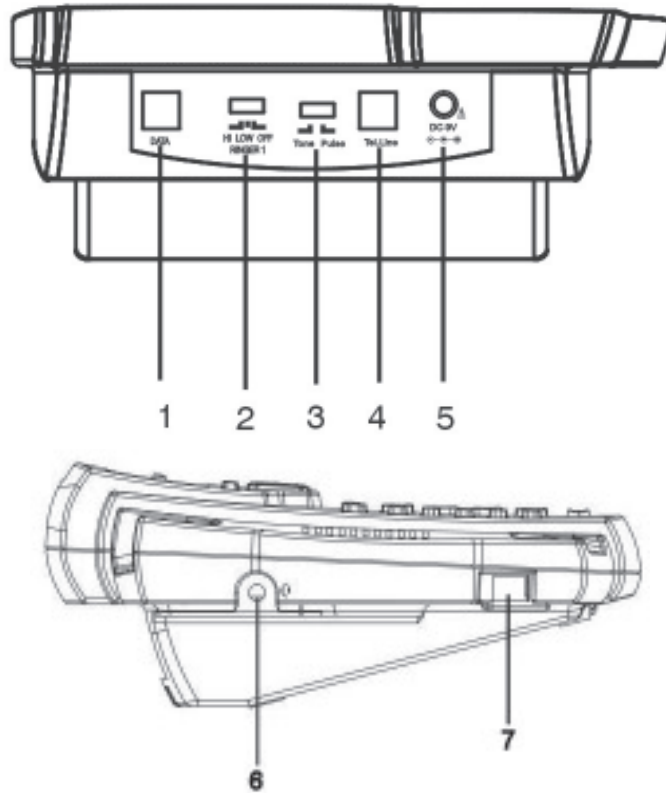

|   |                      |
|---|----------------------|
| 1 | Data Jack            |
| 2 | Ringer Volume Switch |
| 3 | Dialing Mode Switch  |
| 4 | Telephone Line Jack  |
| 5 | Adapter Jack         |
| 6 | Headset Jack         |
| 7 | Handset Jack         |



# INSTALLATION

## BOX CONTENTS

Verify that the following items are in the box.

- Telephone
- Handset
- Handset Cord
- Line Cord
- 3 AA Batteries
- Power Adapter
- Instruction Manual

## BATTERY INSTALLATION

The 9120 telephone requires 3 AA size 1.5 V batteries for the LCD display. To install the batteries, follow the steps below:

1. Remove the battery cover. The cover is located underneath your phone.
2. Insert 3 AA size 1.5 V batteries. Be careful to observe the polarity markings in the battery compartment.
3. Replace the battery compartment cover.

## DIALING MODE

The 9120 dial mode switch is on the back of the phone as shown on the previous page.

- If your telephone line supports touch-tone dialing, put the switch in the "T" position. This is the default position from the factory.
- If your telephone line requires rotary (Pulse) dialing, put the switch in the "P" position.
- If you are unsure which system you have, set the switch to the **TONE** position. Lift the handset. When you get a dial tone, dial a telephone number. If the dial tone continues, move the switch to **PULSE**, and then dial the telephone number again.

**Note:** When in PULSE mode, holding the \* key for approximately 3 seconds will switch to Tone dialing for the duration of the call.

## WALL MOUNT

1. The 9120 ships configured for wall mounting. No changes are necessary.
2. Connect the power adapter. The power adapter connects to the jack marked DC 9V on the back of the phone. Plug the large part of the adapter into the wall outlet. Use only a 9V DC, 300mA, center positive Class 2 adapter. The adapter is necessary for LCD backlighting.
3. Connect the line cord. The line cord connects to the jack marked Tel. Line on the back of the phone.
4. Mount the phone on the wall jack.
5. Plug the coiled cord into the handset, and then plug the other end of the cord into the handset jack.
6. Place the handset on the base

### DESK MOUNT

1. Press in the two areas shown below to release the desk stand.
2. Rotate the desk stand into the desk mounting position as shown below.
3. Connect the power adapter and the line cord. See Steps 2 and 3 in the WALL MOUNT instructions.
4. Plug the coiled cord into the handset, and then plug the other end of the cord into the handset jack.
5. Place the handset on the base.

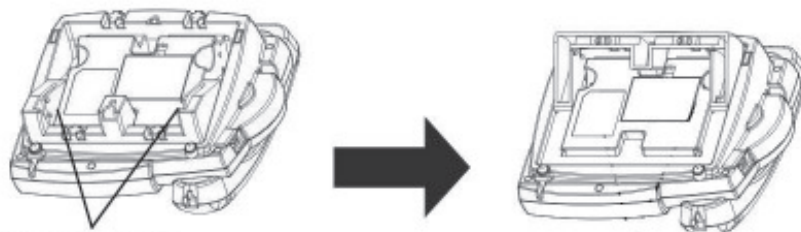

**Press here to  
unlock desk stand**

### ANSWERING MACHINE

1. Connect the LINE jack of the answering machine to the wall telephone jack.
2. Connect the Tel. Line jack of the 9120 to the PHONE jack of the answering machine.
3. Set the answering machine to answer after 2 or more rings.

### RINGER VOLUME

Set the Ringer Volume Switch to your desired loudness. This switch is on the back of the 9120. Ringer volume can be set to Hi, Low or Off.

**NOTE:** If the ringer volume is set to OFF, it is very easy to miss calls.

### MODEMS AND FAX MACHINES

These devices may be plugged into the Data jack on the back of the 9120.

## UNIT SETUP

Use **MENU** to enter the setup screen.

1. Press **MENU**. *PHONE BOOK* appears on the display. The Phone Book is covered in a later section.
2. Press **▼**. When *CALL WAITING* appears, press **ENTER**. Then use **▼** to toggle this feature ON or OFF. If this is set to OFF, Caller ID information will not be displayed for a Call Waiting call. Press **ENTER** to exit.
3. Press **▼**. When *DATE FORMAT* appears, press **ENTER**. Then use **▼** to select either Month-Day (MM-DD) and Day-Month (DD-MM). Press **ENTER** to exit.
4. Press **▼**. When *HOURLY FORMAT* appears, press **ENTER**. Then use **▼** to select either 12 hour or 24 hour time display. Press **ENTER** to exit.
5. Press **▼**. When *SET FLASH* appears, press **▼** to select between 600ms, 300 ms, 120 ms and 100ms. Press **ENTER** to exit.
6. Press **▼**. When *SET AREA CODE* appears, use the keypad to enter the area code in which the phone will be used. This is necessary so that the # key can change dialing formats (7 digits, 10 digits, 11digits).
7. Press **▼**. When *SET LANGUAGE* appears, press **▼** to select between USA-UK (English), FRENCH and SPANISH. Press **ENTER** to exit. Note that pressing **ENTER** now returns the phone to the idle screen.

**NOTE:** If you have Caller ID service, the time will be automatically set. Use Step 8 only if you do not have Caller ID. If you wish to display the Day of the Week, you will need to set the year since Caller ID does not include this.

8. Press **MENU**. Then press **▼** or **▲** until *SET TIME* appears. Press **ENTER** to set the time.
  - a. The “tens” digit in the hour is flashing. Use **▼** or **▲** to set this digit. Then press **ENTER**.
  - b. The “ones” digit in the hour is flashing. Use **▼** or **▲** to set this digit. Then press **ENTER**.
  - c. The “tens” digit in the minute is flashing. Use **▼** or **▲** to set this digit. Then press **ENTER**.
  - d. The “ones” digit in the minute is flashing. Use **▼** or **▲** to set this digit. Then press **ENTER**.
  - e. The “tens” digit in the month is flashing. Use **▼** or **▲** to set this digit. Then press **ENTER**.
  - f. The “ones” digit in the month is flashing. Use **▼** or **▲** to set this digit. Then press **ENTER**.
  - g. The “tens” digit in the day is flashing. Use **▼** or **▲** to set this digit. Then press **ENTER**.
  - h. The “ones” digit in the day is flashing. Use **▼** or **▲** to set this digit. Then press **ENTER**.
  - i. The “tens” digit in the year is flashing. Use **▼** or **▲** to set this digit. Then press **ENTER**.
  - j. The “ones” digit in the year is flashing. Use **▼** or **▲** to set this digit. Then press **ENTER**.
  - k. The cursor for the day of the week will begin flashing. Use **▼** or **▲** to toggle this on or off.
  - l. Press **MENU** to return to the idle screen.

**NOTE:** LCD Contrast may also be set using the Contrast button on the LCD screen.

9. Press **MENU**. Then press ▼ or ▲ until *SET CONTRAST* appears. Press **ENTER** to set the contrast. Use ▼ or ▲ to set the contrast. There are 8 choices available. Press **ENTER** to exit to idle screen.
10. Press **MENU**. Then press ▼ or ▲ until *BACK LIGHT* appears. Press **ENTER**. The display will show *BACK LIGHT TIME*. Press **ENTER**. The display will show the back light time. Use ▼ or ▲ to select between 30 sec, 20 sec, 10 sec or OFF. Press **ENTER**. The display will show *BACK LIGHT TIME*. Press ▼ or ▲. The display will show *OFF HOOK LIGHT*. Press **ENTER**. The display will show the light time. Use ▼ or ▲ to toggle between *FOR SECONDS* (The light will remain on for the backlight time) or *ALL THE TIME* (The light will remain constantly on). Press **ENTER**. Press **MENU**.

**NOTE:** Backlighting will only function if the AC adapter is connected.

# **BASIC OPERATION**

## **RECEIVING A PHONE CALL**

When the phone rings, lift the handset to begin your conversation. You can adjust the volume of the caller's voice by using the sending volume switch on the right side of the telephone.

## **PLACING A PHONE CALL**

1. Lift the handset and wait for a dial tone.
2. Dial the telephone number you wish to call. The number will appear on the display window.

## **PREDIAL**

1. While the handset is on hook, enter the desired telephone number using the key pad. The number will appear in the display.
2. To dial the displayed number, lift the handset.

## **HEADSET**

The 9120 supports headsets with 2.5mm plugs. To use a headset, plug it into the jack on the left side of the phone. The handset is inactive as long as the headset is plugged into the jack. The headset is active whenever the handset is off hook. Calls can be made and received with the headset.

## **CALL TIMER**

Approximately 5 seconds after the beginning of a call, a call timer will appear on the display.

# FEATURE BUTTONS

## **REDIAL/PAUSE BUTTON**

1. To redial the last number dialed, come off hook and press **REDIAL**.
2. The selected number (32 digits maximum) will be redialed.

To review dialed numbers.

1. While on hook, press **REDIAL**.
2. The display will show the last number dialed.
3. Use ▲ or ▼ to scroll through the list of dialed numbers. The last 15 dialed numbers are stored.
4. To dial the displayed number, go off hook. The number will be dialed after approximately 3 seconds.

While storing a number into memory dial, pressing this button will insert at pause.

## **FLASH BUTTON**

This telephone provides a line break signal for accessing PABX services or for use of Call Waiting from your local telephone company. If you have Call Waiting service, you can use the Call Waiting function per the following instructions.

1. While having a conversation, another party calls and you hear a tone.
2. Press **FLASH** once and release. The first conversation is placed on hold and the second call can be answered.
3. Press **FLASH** again and release. You may speak to the first caller again and the second call is placed on hold.

## **AUTO DIAL BUTTON**

Allows dialing of numbers in two touch memory.

## **MUTE BUTTON**

Press **MUTE** to speak without the person on the phone hearing your conversation. "MUTE" will show in the display. To resume the conversation, press **MUTE**.

## **MENU BUTTON**

Press this button to access the Phone Book or to enter setup mode.

## **DELETE BUTTON**

Use this button to delete characters on the display.

## **SAVE BUTTON**

Use this button to store numbers in memory or the Phone Book.

## **ENTER/DIAL BUTTON**

Use this button to confirm choices.

### **MEMORY 1 and MEMORY 2 BUTTONS**

These buttons are used to access the one-touch speed dial memory. See the **SPEED DIAL** section of this manual for specific instructions.

### **MESSAGE BUTTON**

If you have a voice mail service, the large red indicator above the display will flash to alert you that you have new messages. The display will also show an icon of an envelope. The 9120 will only detect FSK message waiting signals.

Press **MESSAGE** to retrieve your messages. This button will dial out \*98 which is a common code to retrieve messages. If your service requires a different code, you can program the **MESSAGE** button by following the instructions for programming one-touch memory in the Speed Dial section.

### **HOLD BUTTON**

1. Press **HOLD** and hang up the handset. **HOLD** will light and remain lighted until you resume your conversation.
2. To resume your conversation, lift the handset or that of any extension phone on the same line. The **HOLD** indicator will go out and your call can continue.

# SPEED DIAL

The 9120 has 2 one-touch and 10 two-touch memories.

## STORE NEW NUMBERS IN MEMORY 1 AND MEMORY 2

There are three ways to store numbers in the one-touch locations.

### Method 1

1. Press **SAVE** until the display shows "-->".
2. Enter the number to be stored.
3. Press **SAVE**.
4. The display will show "-->?"
5. Press **MEMORY 1** or **MEMORY 2**.
6. The display will show "SAVE OK".

### Method 2

1. Place the phone on hook.
2. Enter the number to be stored.
3. Press and hold **MEMORY 1** or **MEMORY 2** until the display shows "SAVE OK."

### Method 3

1. Place the phone on hook.
2. Use the ▲ or ▼ key to display the desired number from incoming calls or dialed calls.
3. Press and hold **MEMORY 1** or **MEMORY 2** until the display shows "SAVE OK."

## DIAL A NUMBER FROM MEMORY 1 OR MEMORY 2

Go off hook, and press the memory button. The number will be dialed out.

## REVIEW THE CONTENTS OF A MEMORY BUTTON

While on hook, press the memory button. The display will show the memory contents.  
To dial this number, go off hook.

## STORE NEW NUMBERS IN TWO-TOUCH LOCATION

To store a number in the two-touch locations.

1. Press **SAVE** until the display shows "-->".
2. Enter the number to be stored.
3. Press **SAVE**.
4. The display will show "-->?"
5. Press the desired location (1 - 9).
6. The display will show "SAVE OK".

## DIAL A NUMBER FROM TWO TOUCH MEMORY

Go off hook, and press **AUTO DIAL**. Then press the location (1 - 9). The number will be dialed out.



## REVIEW THE CONTENTS OF A TWO-TOUCH MEMORY

While on hook, press and hold the location button (1 - 9) or press **AUTO DIAL** and then press the location button. The display will show the memory contents. To dial this number, go off hook.

# PHONE BOOK

The phonebook can store up to 70 names and numbers.

## ADDING AN ENTRY TO THE PHONE BOOK

1. Press **MENU**.
2. The display will show PHONE BOOK.
3. Press **ENTER**.
4. The display will show REVIEW>>.
5. Press **▼**.
6. The display will show ADD>>
7. Press **ENTER**.
8. Use the keypad to enter the number. A maximum of 20 digits may be stored. Use **◀** or **DELETE** to delete digits.
9. Press and hold **ENTER** until the cursor flashes in the name area.
10. The cursor will begin to blink on the name line.
11. Use the keypad to enter the name.
12. Press and hold **ENTER** until the cursor flashes in the number area. You can now enter another number into the phone book. Follow steps 7 - 11 to do this. If you do not wish to enter another number, press **MENU**.

## REVIEWING PHONE BOOK ENTRIES

There are two ways to review entries in the phone book. You may scroll through the listings one by one or you may go directly to a particular number.

To scroll through the listings follow the steps below.

1. Press **MENU**.
2. The display will show PHONE BOOK.
3. Press **ENTER**.
4. The display will show REVIEW>>.
5. Press **ENTER**.
6. Use **▲** or **▼** to scroll through the entries. You may also enter a letter with the keypad and skip directly to the first entry beginning with that letter.

If you know the sequence number of the entry in the phone book, press the number and **#** while on hook. For example, entering "3#" will display the third entry in the phone book. You can then use **▲** or **▼** to scroll through the entries. Entries in the phone book are stored in order of entry. They are NOT stored in alphabetical order.

## DIALING FROM THE PHONE BOOK

To dial from the phone book, first display the desired number as described above. Then come off hook and the number will be dialed.

### DELETING A PHONE BOOK ENTRY

With the number displayed, press **DELETE**. The display will show "DELETE?" Press **DELETE** again to delete the entry. Press **ENTER** to cancel.

### STORING A CALLER ID RECORD IN THE PHONE BOOK

1. Use **▲** or **▼** to display the number.
2. Press and hold **ENTER** until the first character of the name begins to flash.
3. Make any desired changes to the name using **▲** or **▼** to move the cursor, **DELETE** to delete letters and the keypad to add letters.
4. Press and hold **ENTER** until the cursor flashes in an empty number area.
5. Press **MENU**.

## CALLER ID

Caller ID service will display the name and number of callers. The 9120 is also compatible with Caller ID on Call Waiting (CIDCW). Using this service allows you to know who is calling even during another call. Both Caller ID and CIDCW are services provided by the local telephone company. You must be subscribed to these services to see Caller ID information on the 9120.

### RECEIVING CALLS

When the telephone is not in use and a new call is received, the display will show the phone number, the caller's name, and the call date and time. A "+" symbol will appear in the upper right corner of the display if a call has come in more than once.

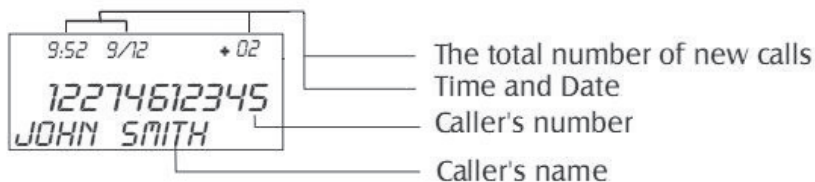

### PRIVATE CALLS

The message below will display when a caller has blocked delivery of his name or number.



## CALLER ID ON CALL WAITING

Call-waiting service alerts you to a new call by playing a tone while you are on a call. Call Waiting Caller ID not only tells you there is another call waiting, but lets you know who the caller is before the call is answered. The name and number of the incoming call will be shown on the display.

Press **FLASH** to place the first call on hold and answer the new call. Press **FLASH** again to return to the first call.

## REVIEWING CALLS

1. While on hook, press ▲ or ▼ to see the stored calls. The 9120 stores up to 99 calls.
2. When the end of the call records is reached, the display will show [END OF LIST ].

## DELETING CALLS

If more than 99 calls have been received by the 9120, the oldest records will be dropped to make room for the new calls. To prevent this, calls can be manually deleted. Individual calls can be deleted or all calls can be deleted. To delete calls, follow the instructions below.

1. While on hook, press ▲ or ▼ to see the stored calls.
2. With the desired call displayed, press **DELETE**.
3. The display shows DELETE ?
4. Press **DELETE** or **ENTER** to delete the number. Press any other key to exit.

To delete all calls follow the instructions below.

1. While on hook, press ▲ or ▼ to see the stored calls.
2. With a call displayed, press and hold **DELETE**.
3. The display shows ALL DELETE ?
4. Press **DELETE** to delete all the numbers. Press any other key to exit.

## CALL BACK

It is possible to dial directly from the display.

1. While off hook, press ▲ or ▼ to see the calls.
2. With the desired call displayed, press **ENTER** to dial out the number. If an Area Code was entered during the unit setup, the # key can be used to change the dial format between 7, 10 and 11 digits. With the number displayed, press # to add a 1 for long distance. Press # again to display only 7 digits for local dialing. Press # again to return to 10 digits.

Numbers can also be selected while on hook. They will be dialed when the phone is taken off hook.

# TROUBLESHOOTING

**If you have any problems with your telephone service**, determine if the problem is with your unit or the telephone company lines **BEFORE CALLING THE TELEPHONE COMPANY**. Always disconnect the power adapter, telephone line and batteries and reinstall them before calling for service. The telephone company may charge you for a service call if the problem is caused by your telephone.

## **PHONE DOES NOT RING**

1. Line cord is disconnected at telephone outlet or at telephone.
2. Phone is off hook. Make certain the hookswitch is depressed when the handset is in the cradle.

## **NO DIAL TONE**

Wire is disconnected at telephone or at wall jack. Test the telephone in a different wall jack. If it works, the first jack may be defective.

## **BLANK SCREEN**

1. Check if the adapter is connected properly and that batteries are installed.
2. Press the Contrast button to see if contrast level is set correctly.

## **CALLERS ARE NOT DISPLAYED ON THE SCREEN**

1. Verify that you have subscribed to the appropriate service (Caller ID and Call Waiting Caller ID) from your telephone company. If you only subscribed to Caller ID service the unit will not display call waiting caller ID information.
2. Check if your answering machine is set to answer before 2 rings.

## **NO CALLER INFORMATION IS DISPLAYED WHEN HEARING THE CALL WAITING BEEP**

1. Verify that you have subscribed to Call Waiting Caller ID service from your telephone company.
2. Verify that Call Waiting is turned on. See Step 2 of the UNIT SETUP section of this manual.

## **MESSAGE ERROR HAPPENS FREQUENTLY**

Caller information was not transmitted properly. Check with your telephone company to see if there is a problem with your phone line.

# TELEPHONE REPAIR

**DO NOT ATTEMPT TO REPAIR THIS PRODUCT YOURSELF.** Telephones manufactured by CORTELCO must be returned to us for repair.

**You can return your telephone to CORTELCO** for repair or replacement in accordance with our LIMITED WARRANTY.

CORTELCO warrants **THIS PRODUCT** against defects in material and workmanship in accordance with our LIMITED WARRANTY. If your telephone is returned for repair, include a copy of your sales receipt containing the date-of-purchase. **DO NOT INCLUDE THE ORIGINAL SALES RECEIPT.**

**If date-of-purchase is not included,** the factory date printed on the label on the bottom of your telephone will be used as the date-of-purchase. The factory date allows six months for distribution and sale of this product.

**If you return your telephone for repair,** the warranty period is not extended. The original date-of-purchase continues to apply to your warranty.

**OUT-OF-WARRANTY REPAIR** We will repair this product for a nominal fee after the LIMITED WARRANTY has expired if you send it to us in a complete and undamaged condition. The repaired unit will be shipped to you C.O.D., freight collect.

**RETURN-FOR-REPAIR PACKAGING** If you are returning a unit to us for repair, package it carefully, preferably in the original carton. Be sure to include your return address, a copy of the sales receipt showing date-of-purchase, and a note describing the problem you have with your Telephone. Shipping must be prepaid. If the telephone is in warranty, it will be repaired or replaced, at our option, at no cost to you, and it will be returned shipping prepaid.

Ship your telephone (shipping prepaid) to:

CORTELCO  
REPAIR CENTER  
1703 SAWYER ROAD  
CORINTH, MS 38834

## FCC INFORMATION

**Part 68** is a Federal regulation which requires equipment to be tested and registered with the FCC prior to its connection to the network. This equipment complies with Part 68 of FCC rules. On the bottom of the telephone is a label that contains, among other information, the FCC Registration Number and the Ringer Equivalence Number (REN) for this equipment. You must, upon request, provide this information to your telephone company.

The **Ringer Equivalence Number(REN)**, which is used to determine the number of devices you may connect to your phone line, indicates the amount of power that your telephone draws from the telephone company line during ringing. If you have more than one telephone (or other terminal device) connected to the telephone company line, you should total the RENs, and be sure that the total is not more than five. Your telephones may not ring if the total is more than five. Also, in some rural locations, your telephone may not ring if the REN total is more than three.

**RESTRICTIONS** You must not connect your telephone to coin-operated lines or party lines.

**INSTALLATION** This model telephone must be connected to the telephone company lines through a modular jack. The required USOC for the modular jack is RJ11C for desk mounting and RJ11W for wall mounting. The USOC number is printed on the label on the bottom of your telephone.

**HEARING-AID COMPATIBILITY** The handset on your telephone will work with magnetically-coupled hearing aids. You can use a hearing aid equipped with a T (Telephone) switch.

**IN CASE OF TROUBLE** If your telephone should cause problems on the telephone line, the telephone company can temporarily disconnect your service. The telephone company must then notify and allow you to correct the problem.

The telephone company may from time to time change its lines or equipment. They must notify you if planned changes will affect your telephone service, to allow you to take steps to prevent interruptions.

This telephone complies with Part 15 of the FCC Rules. In the unlikely event that interference occurs, move the telephone and/or radio, television, etc. to increase the separation distance.



## LIMITED WARRANTY

If you purchased this product new in the U.S. or Puerto Rico, **CORTELCO** warrants it against defects in material and workmanship for a period of one (1) year from the date of original purchase. This warranty is in lieu of all other express warranties. During the warranty period, **CORTELCO** agrees to repair or, at its option, replace the defective product, or any part of it without charge for parts or labor. This is your exclusive remedy. This warranty does not cover damage resulting from accident, misuse, abuse, improper installation or operation, lack of reasonable care, the affixing of any attachment not provided by **CORTELCO** with the product and loss of parts. The warranty is voided in the event any unauthorized person alters or repairs the unit.

Telephone companies use different types of equipment and offer various types of services to customers. **CORTELCO does not warrant that this product is compatible with the type of equipment of any particular phone company or the services provided by it.**

**CORTELCO** DISCLAIMS ANY IMPLIED WARRANTY, INCLUDING THE WARRANTY OF MERCHANTABILITY AND THE WARRANTY OF FITNESS FOR A PARTICULAR PURPOSE, AS OF THE DATE ONE YEAR FROM THE ORIGINAL PURCHASE OF THE PRODUCT. **CORTELCO** ASSUMES NO RESPONSIBILITY FOR ANY SPECIAL, INCIDENTAL OR CONSEQUENTIAL DAMAGES.

THIS WARRANTY GIVES YOU SPECIFIC LEGAL RIGHTS, AND YOU MAY HAVE OTHER RIGHTS WHICH VARY FROM STATE TO STATE. SOME STATES DO NOT ALLOW THE EXCLUSION OR LIMITATION OF SPECIAL, INCIDENTAL OR CONSEQUENTIAL DAMAGES OR LIMITATIONS ON HOW LONG AN IMPLIED WARRANTY LASTS, SO THE ABOVE EXCLUSION AND LIMITATION MAY NOT APPLY TO YOU.

If failure occurs and your telephone is in warranty, service shall be provided by returning it to **CORTELCO - Repair Center, 1703 Sawyer Road, Corinth, Mississippi 38834, shipping prepaid.** The product will be repaired or replaced if examination by us determines the product to be defective. Telephones received damaged as a result of shipping will require you to file a claim with the carrier.